

Keyboard Manual

Version.707

Table of Contents

- I. Overview**
- II. Functions**
- III. Keyboard Panel**
- IV. Operation of the Keyboard**
- V. DVR Connection & Operation Setting**

I. Overview:

The speed dome camera control keyboard is a peripheral product for wide speed domes, decoders, and other terminal receivers. The EIA/RS – 485 electric interface is used to connect a control keyboard and a receiver in the maximum communication distance of 1.2km. The keyboard controls 256 domes or decoders at most if no bus-powered device is driven. A speed dome camera can be controlled and installed using a control keyboard.

II. Functions:

The control keyboard has the following functions:

1. Setting an address range for dome cameras or decoders: 0~255
2. Controlling each function of the cameras directly
3. Entering the speed dome menu for option setting
4. Operating the built-in control panel of the speed dome camera
5. Setting and adjusting preset points and tracks of the dome camera
6. Controlling the dome camera either manually or automatically and changing the camera's default settings by adjusting the menu of a specific camera
7. Controlling zoom, focus, and iris manually
8. Controlling multiple dome cameras
9. Having built-in multi-protocol for selection

III. Keyboard Panel:

3.1 3 axis Joystick Front Panel

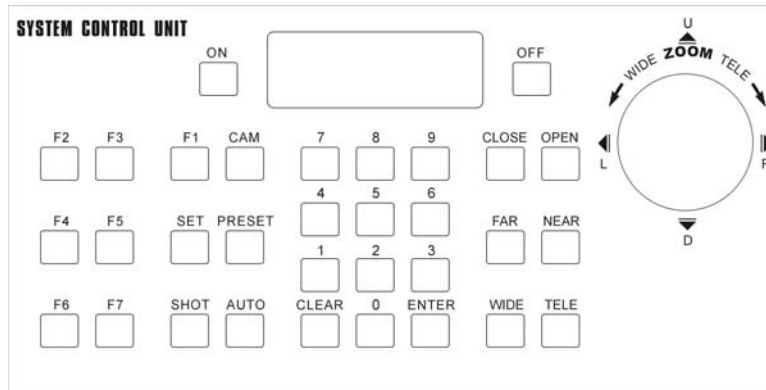

3.2 2 axis Joystick Front Panel

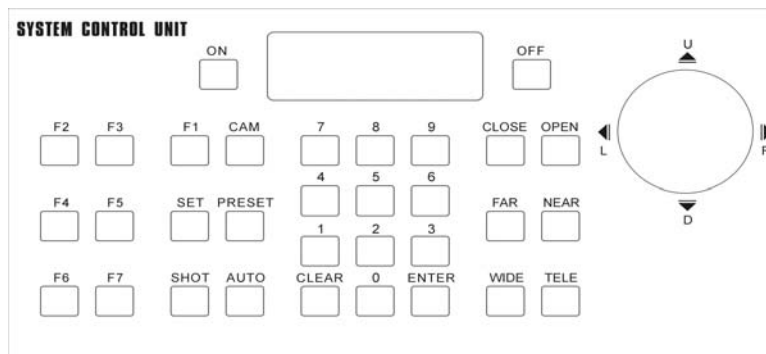

A speed control joystick, LCD, and keys are on the front panel of the control keyboard. The LCD is designed to display system status and operation information and the joystick is designed to control the panel for 4-directional (Up, Down, Left, and Right) speed movement and manual positioning.

3.3 Keys:

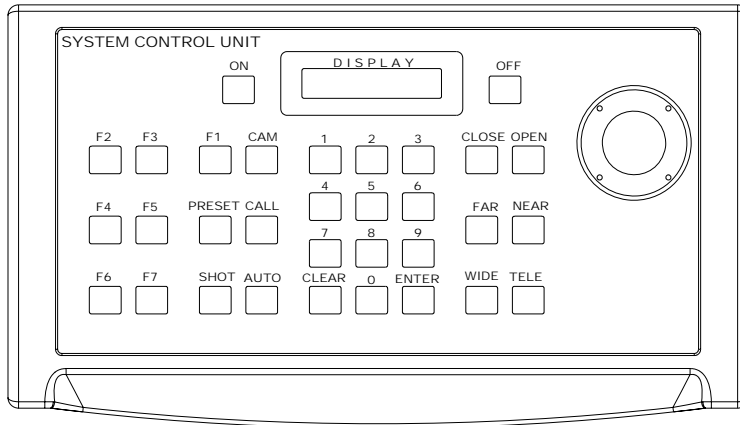

1. [CAM] Selection of the speed dome camera
2. [SHOT] Preset Point Group setup and activate
3. [SET] Preset point setting
4. [PRESET] Preset point calling
5. [ON] Function key on
6. [OFF] Function key off
7. [0] —[9] Digital Number pad
8. [CLEAR] Clear key
9. [ENTER] Confirmation Key
10. [AUTO] Auto horizontal scan
11. [OPEN] Large lens IRIS
12. [CLOSE] Small lens IRIS
13. [WIDE] Short lens focus
14. [TELE] Long lens focus
15. [FAR] Far focusing
16. [NEAR] Closeup focusing

3.4 Back Panel:

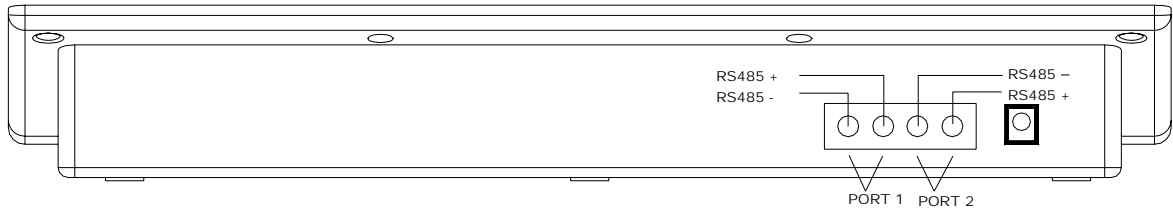

3.4.1 Power input port: This port is used to connect external regulated power supply and input DC12V voltage.

3.4.2 RS485 Com port: This port is used to connect the speed dome and the master and slave keyboards. See the following figure for their connection.

Single Keyboard

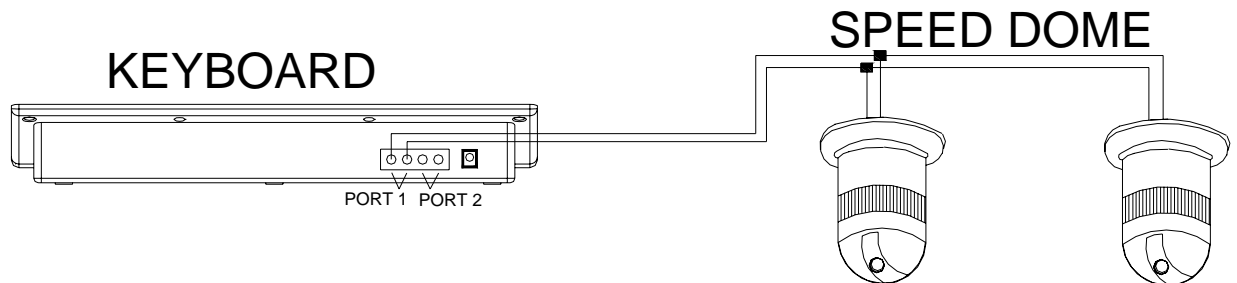

Connection of the Master Keyboard and the Slave Keyboard

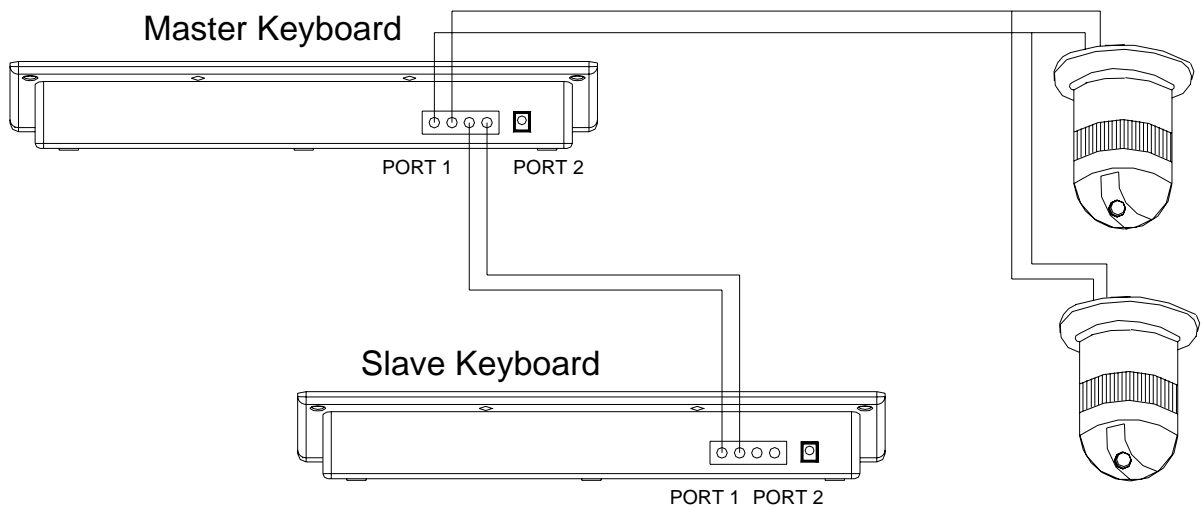

IV. Operation of the Keyboard

Complete the connection of the speed dome and the keyboard.

(Remember that failure to connect the speed dome and the keyboard properly may result in an inoperative keyboard.) After the connection is completed, you may start to operate the speed dome using the keyboard.

4.1 Keyboard Communication Protocol Setup

The factory default of the keyboard communication protocol is set in "EYEVIEW" default values and our keyboards are provided with 5 speed dome communication protocols: 1.EYEVIEW 2. PELCO D-2400 type 3.PELCO P-9600 type 4.PELCO P-4800 type 5.ALEC

Refer to the following information for changing keyboard communication protocols:

4.1.1 Display Keyboard Communication Protocols

Press + 61 + keys to display the current keyboard communication protocol. Press to exit.

4.1.2 Change Keyboard Communication Protocols

Press + 61 + to display the current keyboard communication protocol. To change the communication protocol, use and keys to select communication protocols until the communication protocol you required is selected. Press to save and exit.

4.2 Selection of Speed Dome Camera

Confirm the ID address of the speed dome camera you want to control and refer to the Speed Dome Camera Manual for ID address setup. You may enter the same address to control the corresponding speed dome camera by following the operation procedure:

LCD displays NNN: Indicates the current dome number under operation

4.2.1 Select to Control the Speed Dome Camera:

Enter: **CAM** + **NNN** + **ENTER**

Display: **Cur CamID : NNN**

NNN: Users may enter one number from Number 0 ~255 as the number of the speed dome cameras. The speed dome camera you select to control appears on the LCD screen after one number is entered.

4.2.2 Set up the Speed Dome Preset Points:

A. Enter: **SET** + **NN** + **ENTER**

B. Display: **Preset No : NNN**

C. NNN: Users may enter one number from Number 1 ~

64(TPOWER) 32(XPOWER) as preset points number.

D. Operation: Move the speed dome to the location you want to set up and set the preset point based on the method used for Point A. The operation method applies to other preset points setting.

4.2.3 Call the Speed Dome Preset Points:

Enter: **PRESET** + **NN** + **ENTER**

Display: **CALL Number : NN**

NN: Preset points, No. 1~ 64(TPOWER) 32(XPOWER) as preset points number.

4.2.4 Delete the Speed Dome Preset Points:

Description: This function is designed to clear the preset points by following the operation procedure:

Enter: + +

Display:

NN: Preset points to be deleted, No. 1~ 64(TPOWER) 32(XPOWER)
as preset points number.

4.2.5 Set up Preset Point Group : Protocol)

(Do not apply to PELCO

Description: This function is designed to scan the preset points in order.
Each group is allowed to set up 16 preset points for the moving speed and
retention time.

For Tpower Speed Dome :

Enter: + +

If you choose EYEVIEW Protocol for one of our speed dome cameras, you
may set up 4 preset point groups by following the operation procedure:

A. Press [SHOT] :

LCD displays:

Enter the preset point groups, No. 1-4, and press the key.

LCD displays:

B. Press [TELE] :

LCD displays: [No:001 Point:001]

Enter one of the preset points of the group ranging from No. 1-50.

C. Press [TELE] : Set up the moving speed

LCD displays: [No:001 Speed:001]

The speed represents the moving speed between two preset points and
is divided into 1-8 phase. (1: fastest speed; 8: slowest speed)

D. Press [TELE] : Set up the retention time

LCD displays: [No:001 Time:001]

The displayed time is the retention time of each preset point and can be
set from 1 to 99 seconds.

E. Press the [TELE] key to go back to step B to set up next point. Press [OFF] to end and save your setting.

For Xpower Speed Dome :

Enter: [SHOT] + [N] + [ON]

If you choose EYEVIEW Protocol for one of our speed dome cameras, you may set up 1 preset point groups by following the operation procedure:

A. Press [SHOT] :

LCD displays: [Input TourNo: 000]

Enter the preset point groups, No. 1, and press the [ON] key.

LCD displays: [Track: 01 Sum: 001]

B. Press [TELE] :

LCD displays: [No:001 Point:001]

Enter one of the preset points of the group ranging from No. 1-32.

C. Press [TELE] : Set up the moving speed

LCD displays: [No:001 Speed:001]

The speed represents the moving speed between two preset points and is divided into 1-8 phase. (1: fastest speed; 8: slowest speed)

D. Press [TELE] : Set up the retention time

LCD displays: [No:001 Time:001]

The displayed time is the retention time of each preset point and can be set from 1 to 99 seconds.

E. Press the [TELE] key to go back to step B to set up next point. Press [OFF] to end and save your setting.

4.2.6 Start Preset Point Group Scanning (Do not apply to PELCO Protocol)

For Tpower Speed Dome :

Enter: [SHOT] N [ENTER]

LCD displays:

XXX: No. 1~4 preset points group scanning. Complete the preset point setup described in Step 4.2.5 before starting preset point group scanning.

For Xpower Speed Dome :

Enter: [SHOT] N [ENTER]

LCD displays:

XXX: No. 1~1 preset points group scanning. Complete the preset point setup described in Step 4.2.5 before starting preset point group scanning.

4.2.7 Activate Pan Scanning:

Description: While this function is activated, the speed dome makes a 360° horizontal rotation.

Activate Pan Scanning: +

Press [AUTO].

LCD displays:

Press the [ON] key to activate Pan scanning.

4.2.8 Deactivate Pan Scanning:

Description: Stop the speed dome rotating at 360 degrees horizontally.

+

Press [AUTO]

LCD displays:

Press the [OFF] key or control the joystick directly to stop Pan scanning.

4.2.9 Horizontal Revolution of 2 Preset Points (Do not apply to PELCO Protocol)

Description: This function is designed to set the speed dome at horizontal revolution in a small zone.

Enter: Press [AUTO].

LCD displays:

Enter a start point for Auto Pan scanning. The start point should be one of the preset points. Complete preset point setting first by following Step 4.2.2.

Press the [ON] key to complete the start point setting.

LCD displays:

Enter a stop point for Auto Pan scanning. The stop point should be one of the preset points. Complete preset point setting first by following Step 4.2.2.

Press the [OFF] key to complete the stop point setting. The speed dome will begin to move at horizontal revolution immediately.

PS: If the start point and the stop point are set at the same preset point, the speed dome will move at 360° horizontal revolution. The start point and the stop point should be selected from one of the 1-50 preset points.

4.2.10 Keyboard " Beep " sound setting

Activate or cancel " beep " sound

[F1] + [67] + [ON]: Enable

[F1] + [67] + [OFF] : Disable

4.2.11 Time Display

Press [F1] + [68] + [ON] to display time setting:

Press [CLEAR] to change time setting,

Press [OFF] to save your new setting.

4.2.12 LCD screen character setting

8 characters can be entered at the second line of LCD screen.

Press [F1] + [69] + [ON] to start character editing,

Press [TELE] , [WIDE] to change characters (A~Z, 0~9)

Press [CLEAR] , [ENTER] to change position,

Press [OFF] to save your new setting,

Press [F1] + [69] + [OFF] to close LCD character display.

4.3 Lens zoom - panoramic image: [WIDE]

Display: *** Zoom Wide ***

4.4 Lens zoom - close-up image: [TELE]

Display: *** Zoom Tele ***

4.5 Lens adjustment - far focusing: [FAR]

Display: *** Far ***

4.6 Lens adjustment - near focusing: [NEAR]

Display: *** Near ***

4.7 Lens iris on: [OPEN]

Display: *** Open ***

4.8 Lens iris off: [CLOSE]

Display: *** Close ***

4.9 Extended Command

N Value No.	Control Object	Keyboard Operation Definition	
		[SET] + N + [ENTER]	[PRESET] + N + [ENTER]
86	Auto slow shuter for S1&S2&S8	OFF	ON
87	IR Filter AUTO for S2&S5&S8		ON
88	IR Filter IN (color mode) S2&S5		ON
89	IR Filter OUT (black-white mode) S2&S5&S8		ON
90	Back light	OFF	ON/AUTO
91	Digit ZOOM	OFF	ON
92	PAN SCAN SETTING		START point
93			STOP point
94	Zoom/Pan speed limit	OFF	ON
95	Camera Manual setting	OFF	ON
97	Preset Tour (preset 1 ~ 16 point)	OFF	ON
98	OSD Display	OFF	ON
99	Auto PAN Scan	OFF	ON

4.11 Protocol Operation Procedure:

- (1) Display the current protocol: [F1] + 61 + [ON]
- (2) Change protocols: Display the current protocol and then select [WIDE] or [TELE]. After a protocol is selected, press [OFF] to set up the selected protocol

to the current protocol. Press any key to cancel and keep the original protocol.

4.12 Master/Slave Control Operation Procedure:

Press [F1] + 62 + [ON] to make PORT 1 as a general communication output port.

Press [F1] + 62 + [OFF] to make PORT 2 as a communication input port for slave device. Connect the control port of slave keyboard to PORT1 of master device and define this keyboard as Master keyboard to control the terminal device via PORT2. See the following figure for the connection.

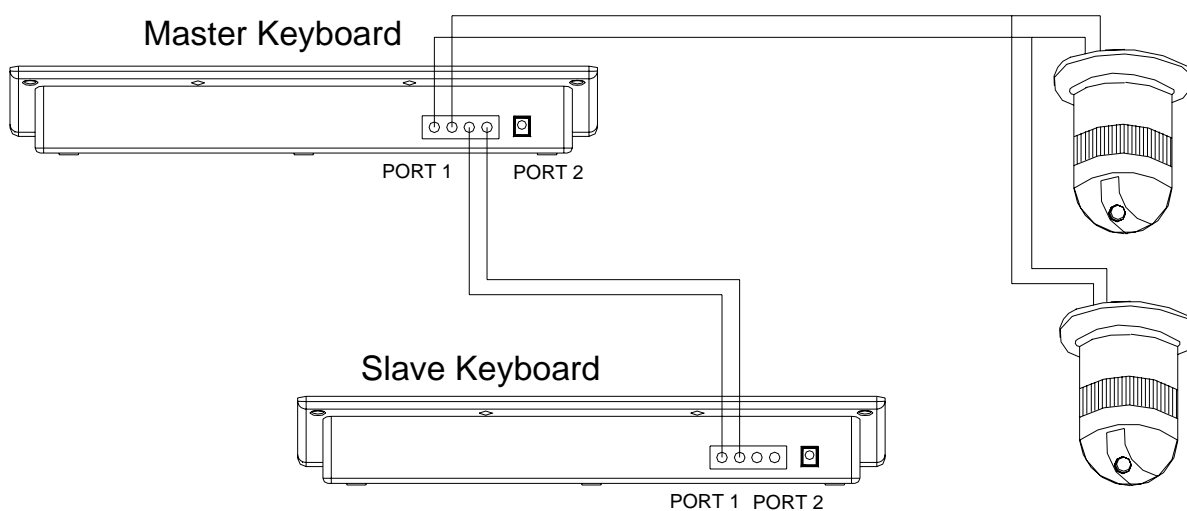

4.13 Refer to the following operation procedure for speed dome options:

- A. Open the menu in accordance with the operation instruction specified in the table.
- B. Use [WIDE]/[TELE] to roll the optical cursor up and down to select options.
- C.. Use [FAR]/[NEAR] to change the selected options.
- D.. After the setting is completed, close the menu in accordance with the operation procedure specified in the table.

*Note: Certain functions listed in 1-11 are decided according to the protocol used and the model numbers of the built-in camera.

4.14 Joystick control Pan / Tilt panel:

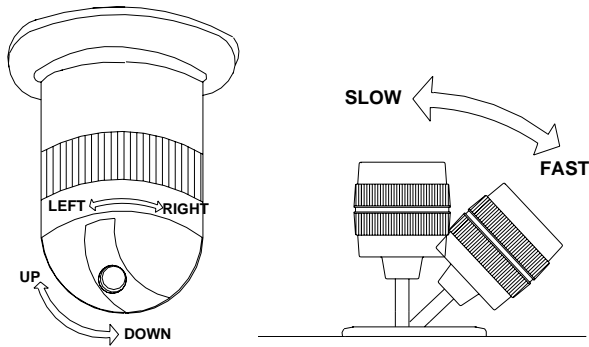

4.14.1 The gearshift joystick is used to control rotation/elevation direction and speed of the Pan / Tilt functions of camera. The angle of the joystick shown in the right-hand side of above figure determines the rotation/elevation speed. The rotation speed can be adjusted evenly by changing the inclination angle of the joystick. During scanning, the camera will automatically focus on the clear object.

4.14.2 A 3D joystick can be used for lens zoom in/out. The movement to the right side is for zoom in and the movement to the left side is for zoom out as shown in the following figure:

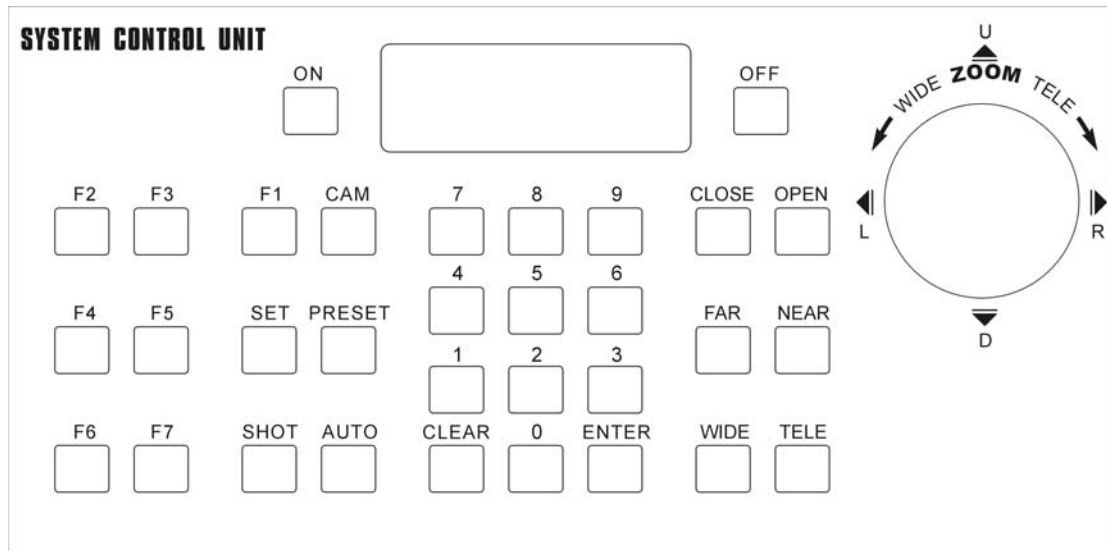

4.15 The LCD will display "Error" if any error occurs it will return to normal status after one second.

A.) Serial Connection

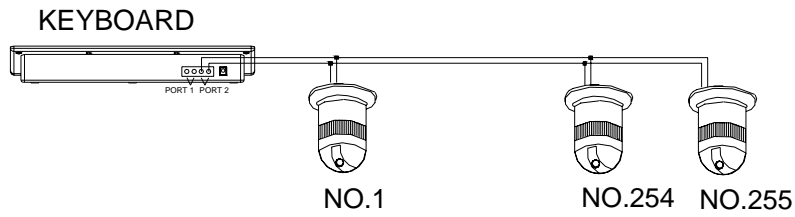

B.) Star Connection

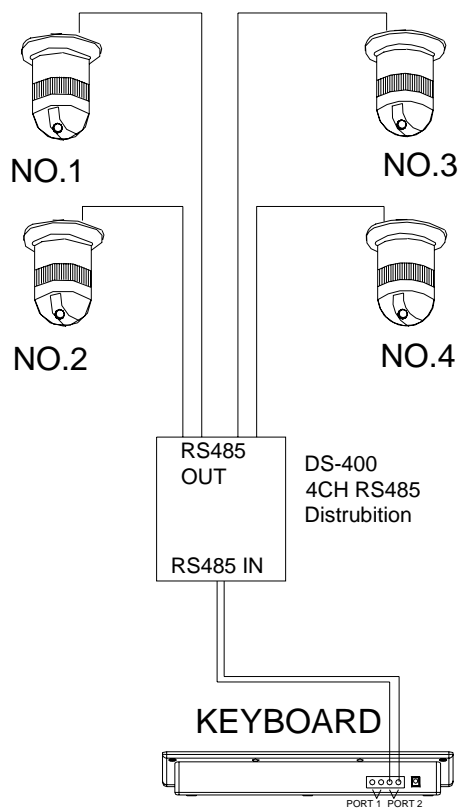

V. DVR connection & speed dome setting

6.1.1 DVR Program setup (SDVR-PRO1004 / SDVR-PRO6016)

Please enter the DVR System Setting menu,

System Setting		
1.	Language	:CHINESE
2.	Video format	:NTSC
3.	KDB ID	:01
4.	Password	: XXXX
5.	Admin Lock	: yes
6.	Time format	: 24 hour
7.	Date format	:Month-Date-Year
8.	Date/Time Set	
9.	Default	:
10.	DVR Version	:VERSION

KDB ID This value can be adjusted from 01 ~ 16. That means the keyboard can control up to 16 DVRs. Please make sure the value isn't repeated if you have several DVR operation at one time. Or Keyboard couldn't identifying which DVR to be controlled.

Single DVR connection



Multiple DVR connection

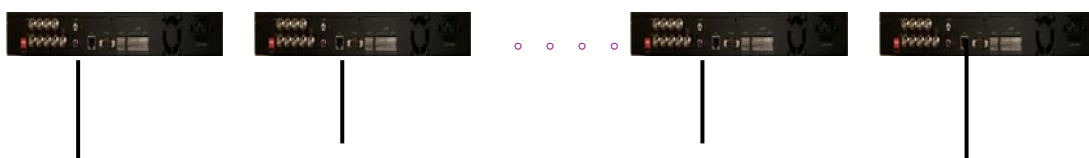

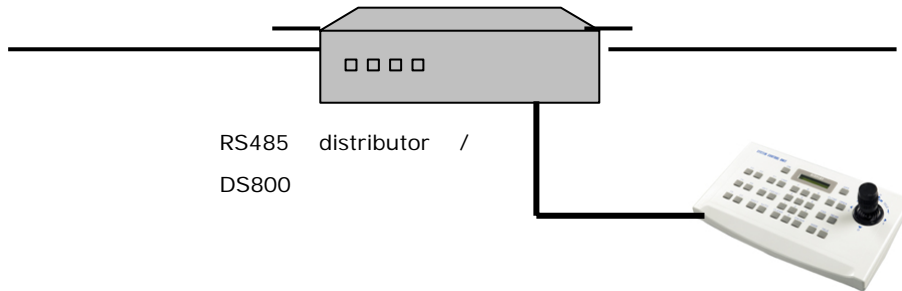

Connect to DVR's ID address:

The keyboard can be controlled up to 16 DVR if the correcting DVR ID is input correctly by pressing:

F3 + **F2** + **N** + **ENTER**

N means DVR's ID address

If the correct DVR ID is selected the LCD screen on the keyboard will show " Cur DVR ID:NNN" The NNN represents the DVR's ID

Example 1: **F3** + **F2** + **1** + **ENTER** , this means the DVR 1 can be controlled by keyboard

Example 2 : **F3** + **F2** + **16** + **ENTER** , this means the DVR 16 can be controlled by keyboard.

6.3 Selection DVR's CHANNEL **F2**+ **N** + **ENTER**

N represent the channel you wanted to select

Press F2 to display DVR's current channel "Cur Channel:000"

You can then press any number (1~16),to change the display channel, the keyboard LCD will show: "Cur Channel:00X"

*x means the number you pressed.

You can also press Enter to display current DVR's ID , and the keyboard LCD will show " Cur DVR ID:NNN"

Example 1: Select Channel 2 you input **F2**+ **2** + **ENTER**

Example 2: Select Channel 16 you input **F2**+ **16**+ **ENTER**

1CH	2CH	3CH	4CH
F2 + 1 + ENTER	F2 + 2 + ENTER	F2 + 3 + ENTER	F2 + 4 + ENTER
5CH	6CH	7CH	8CH
F2 + 5 + ENTER	F2 + 6 + ENTER	F2 + 7 + ENTER	F2 + 8 + ENTER
9CH	10CH	11CH	12CH
F2 + 9 + ENTER	F2 + 16 + ENTER	F2 + 17 + ENTER	F2 + 18 + ENTER
13CH	14CH	15CH	16CH
F2 + 19 + ENTER	F2 + 20 + ENTER	F2 + 21 + ENTER	F2 + 22 + ENTER

6.4 Select the DVR divided pictures:

F3+ **N** + **ENTER**

N represents how you would like the DVR to divide the picture

Example1: Select Quad display, **F3**+ **4** + **ENTER**

Example2: Select 9 channel display, **F3**+ **9** + **ENTER**

Example3: Select 13 channel display **F3**+ **13** + **ENTER**

Example4: Select 16 channel display **F3**+ **16** + **ENTER**

//Make sure you select the correct DVR ID, before you do any setting to it

Press F3 to display how many channel is split on the monitor, the keyboard LCD shows

" Split : 000"

You can press any number to change the channels displayed on the monitor, the keyboard LCD shows

" Split : 00X"

Press Enter to display current Dvr ID , the keyboard LCD shows

" Cur DVR ID:NNN"

6.5 How to enter the Menu

F3 + **ON** + **ENTER** enters the DVR MENU

Keyboard LCD shows : ***** Menu *****

Use WIDE and TELE keys for Up or Down selection

Use OPEN and CLOSE keys for Left or Right selection

Use FAR and NEAR keys for selecting different setting in each tree menu

[F2]+ 0 +[ON] or [F2]+ 2 +[ON] are both Confirming key. You can use either of these commands to confirm the setting.

6.6 DVR function key command,

DVR REC ==> F4 + ENT

DVR PLAY ==> F5 + ENT

DVR PIP ==> F2 + 4 + ON

DVR Freeze ==> F2 + 2 + ON

AUTO ==> F2 + 3 + ON

DVR LOCK ==> F2 + 5 + ON

DVR + ==> F2 + 7 + ON

DVR - ==> F2 + 8 + ON

ENTER ==> FAR

ESC ==> NEAR

目錄

1. 概述
2. 主要功能
3. 鍵盤面板介紹
4. 鍵盤的操作使用
5. 安裝連接
6. **Multiplexer/DVR 連接操作設定**
7. 快速球選單設定

一 概述：

球形攝像機控制鍵盤是與變速智慧球機、解碼器等終端接收器配套的產品。控制鍵盤與接收器之間採用 EIA/RS - 485 電氣介面，在不加匯流排驅動的情況下，一台鍵盤最多可控制 256 台球機或解碼器，鍵盤與接收器的最大通信距離達 1.2Km。利用控制鍵盤可方便地對變速球形攝像機進行控制和設置。

二 主要功能：

控制鍵盤具有下列主要功能：

10. 設定球形攝像機或解碼器的地址範圍：0~255。
11. 能直接控制攝像機的各项功能。
12. 進入快速球內的菜單做選擇設定
13. 可對球形攝像機的內置雲台進行變速操作。
14. 可對球形攝像機進行預置點和巡視軌迹的設置和調用。
15. 可對球形攝像機進行手動或自動控制，並可對特定攝像機通過調用攝像機功能表更改攝像機出廠設置。
6. 手動控制攝像機的變倍、變焦、光圈。
7. 可控制多台球形攝像機。
8. 內置多協定可供選擇。

三、鍵盤面板介紹：

3.1 3 維搖桿正面面板

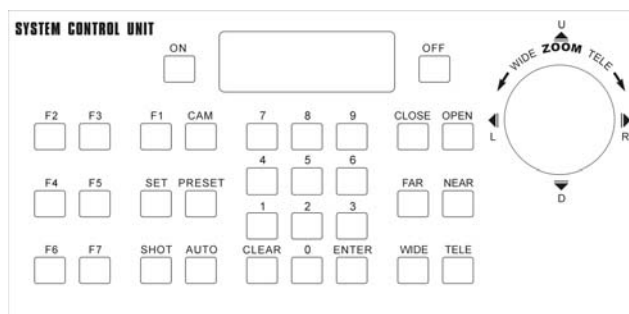

3.2 2 維搖桿正面面板

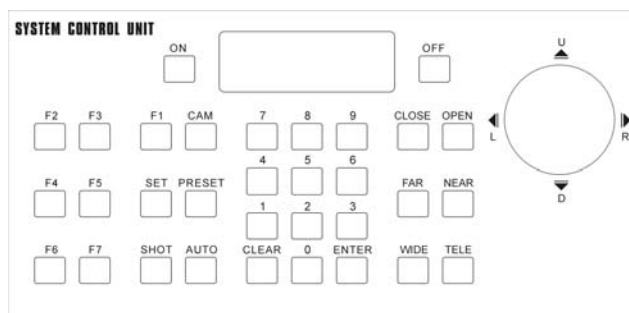

控制鍵盤正面面板上有變速控制搖杆，按鍵和 LCD 顯示幕。顯示幕用於顯示系統狀態及操作資訊。搖杆控制雲臺上、下、左、右作變速運動及手動定點。

3.3 按鍵說明:

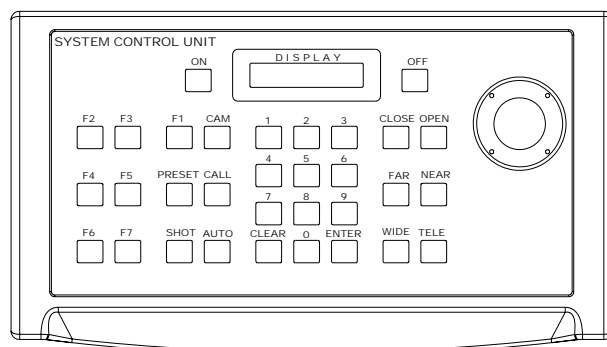

1. [CAM] 快速球攝影機的選擇
2. [SHOT] 設置及調用軌迹
3. [SET] 設定預設點的設置

4. [PRESET] 呼叫預設點
5. [ON] 功能鍵開啓
6. [OFF] 功能鍵關閉
7. [0] —[9] 數位鍵
8. [CLEAR] 清除鍵
9. [ENTER] 確認鍵
10. [AUTO] 雲台自動水平掃描控制
11. [OPEN] 鏡頭光圈大
12. [CLOSE] 鏡頭光圈小
13. [WIDE] 鏡頭焦距短
14. [TELE] 鏡頭焦距長
15. [FAR] 鏡頭聚焦遠
16. [NEAR] 鏡頭聚焦近

3.4 後背板圖示:

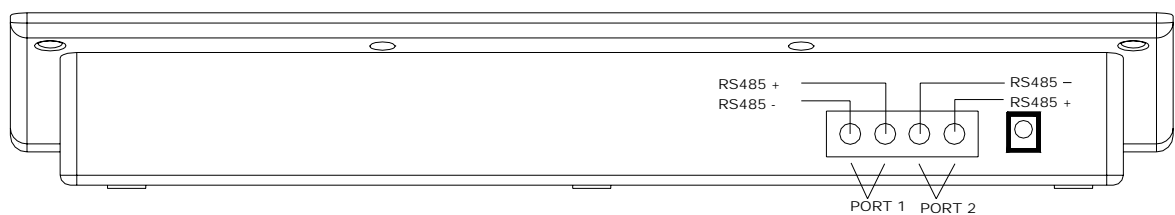

3.4.1 電源輸入端：由此端連接外部穩壓電源輸入 DC12V 直流電壓。

3.4.3 RS485 通信 port：此項功能提供連接快速球的連接端，及在作鍵盤的主副控連接端，連接方式如下圖所示

單支鍵盤

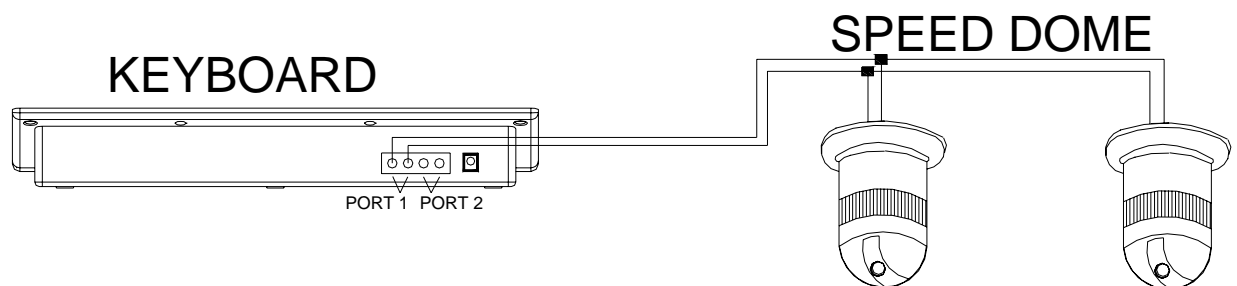

主副控鍵盤連接方式

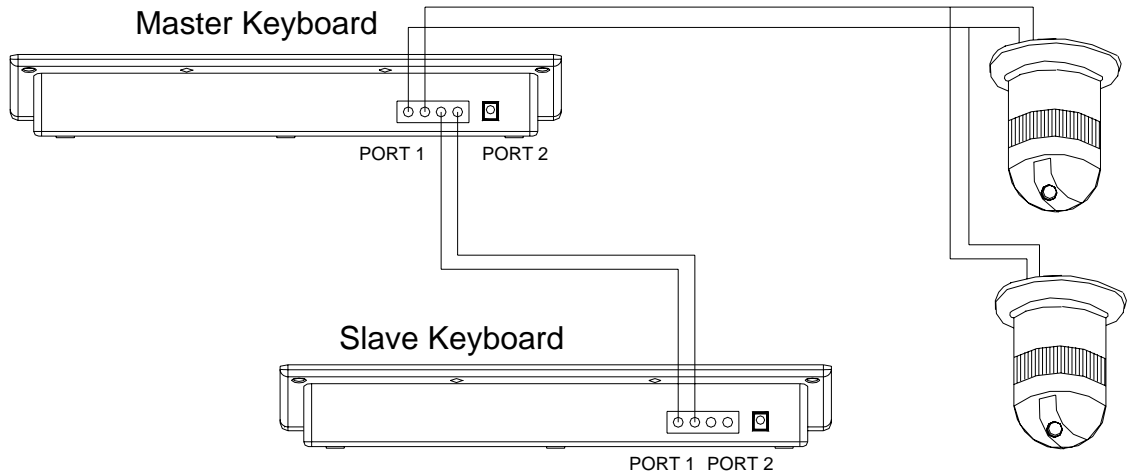

四、鍵盤的操作使用

將快速球跟鍵盤連接完成, (請注意如鍵盤跟快速球之間接線不正確, 將會造成鍵盤操作無法動作的情形), 在上述的動作完成後即可進行鍵盤對快速球的操作

4.1 鍵盤通信協議設定

本鍵盤通信協議出廠值是設定在 " EYEVIEW " 的內定值, 我們鍵盤提共了有 5 種快速球的通信協議, 1.EYEVIEW 2. PELCO D-2400 type 3.PELCO P-9600 type 4.PELCO P-4800 type 5.ALEC

更改鍵盤通信協議如下 :

4.1.1 顯示鍵盤通信協議

請按鍵 **F1** + **61** + **ON**, 此時螢幕上會顯示出當前鍵盤的通信協議, 如果你要退出請按下 **OFF**

4.1.2 更改鍵盤通信協議

請按鍵 **F1** + **61** + **ON**, 此時螢幕上會顯示出當前鍵盤的通信協議, 當你要更改通信協議時, 請使用 **WIDE** 及 **TELE** 鍵做上下選擇通信協議, 如果你選擇到正確的通信協議, 請按下 **OFF** 鍵為儲存及退出程式.

4.2 快速球攝影機的選擇

請先確認你要控制的快速球攝影機的位址碼是多少, 位置碼的設定請參照快速球攝影機的使用手冊, 所以鍵盤只要輸入相同的位址碼即可做控制相對應的快速球攝影機, 操作如下 :

螢幕顯示 **Cur CamID : NNN** **NNN** : 表示當前操作的球機號

4.2.4 選擇控制快速球攝影機：

請輸入： **CAM** + **NNN** + **ENTER**

顯示： **Cur CamID : NNN**

NNN：使用者可以輸入 0 ~ 255 快速球攝影機，輸入完成後在 LCD 螢幕上便會出現你所選擇要控制的快速球攝影機。

4.2.5 設定快速球的預設點：

A. 請輸入： **SET** + **NN** + **ENTER**

B. 顯示： **Preset No : NNN**

C. NNN：使用者可以輸入 1 ~64 預設點的號碼，

D. 操作方式：使用者首先將快速球移動到要設定的位置，再依照 A 點的方式將預設點設定完成，其他設定預設點的操作是一樣。

4.2.6 呼叫快速球的預置點：

請輸入： **PRESET** + **NN** + **ENTER**

顯示： **CALL Number : NN**

NN：預置點號 1 — 64

4.2.4 刪除快速球的預置點：

說明：此功能在於清除快速球的預置點，操作如下：

請輸入： **PRESET** + **NN** + **OFF**

顯示： **CALL Number : NN**

NN：要刪除預置點的位置 1 — 64

4.2.4 設定預置點的族群： (不適用於 PELCO protocol)

說明：此功能在於設定快速球的預置點順序掃描，每個預置點群組可以設定 16 個預置點，其內容可以設定位移的速度及停留的時間。

請輸入： **SHOT** + **N** + **ON**

在我們的快速球攝影機如果你選擇的是 EYEVIEW Protocol，這樣你就可以設定 4 個預置點群組。操作如下：

A. 按下 [SHOT]：

LCD 顯示： **Input TourNo: 000**

請輸入要設定 1~4 的預置點群組號，並按下 **ON** 鍵，LCD 顯示如下

LCD 顯示：**Track: 01 Sum: 001**

B. 按下 [TELE]：

LCD 顯示：[No:001 Point:001]

請輸入預設點群組的預設點，範圍從 1~64 預置點

C. 按下 [TELE]：設定移動速度

LCD 顯示：[No:001 Speed:001]

此速度代表為 2 個預設點之間的移動速度，速度共分為 1 到 8 段，1 為最快速度，8 為最慢速度。

D. 按下 [TELE]：設定停留時間

LCD 顯示：[No:001 Time:001]

此停留時間為每個預設點的停留時間，這個停留時間可以從 1 到 99 秒。

5. 如果要再設定下一個點，請在按一次 [TELE] 鍵，則會跳到步驟 B 繼續設定下一個點，如果按下 [OFF] 鍵則完成及儲存設定

4.2.5、啟動預置點群組掃描 (不適用於 PELCO protocol)

請輸入：[SHOT] N [ENTER]

LCD 顯示：**Input Tour No : XXX**

XXX：1 ~4 的預設點巡航，在要執行這個預置點群組功能之前，必須先將步驟 4.2.4 設定完成。

4.2.6 啟動水平掃描：

說明：啟動此功能將會使快速球做 360 度的水平旋轉

啟動水平掃描：**AUTO** + **ON**

按下 [AUTO] 鍵

LCD 顯示：**Input Tour No : 000**

按 [ON] 鍵，啟動水平掃描按

4.2.7 關閉水平掃描：

說明：停止快速球做 360 度的水平旋轉

AUTO 鍵 + **OFF** 鍵

按下 [AUTO] 鍵

LCD 顯示：

Input Tour No : XXX

按 [OFF] 鍵，停止水平掃描，或直接控制搖桿也可停止。

4.2.8 2 個預設點水平迴轉 (不適用於 PELCO protocol)

說明：此功能在於設定快速球做小區域的水平迴轉

請輸入：按下 [AUTO] 鍵，

LCD 顯示：

Input 1st No : 000

輸入水平自動掃描的起始點，起始點必須選擇預設點(你必須先將預設點設定完成，如 4.2.2 步驟)的其中一點。

按下[ON]鍵即完成起始點的設定。

LCD 顯示：

Input 2nd No : 000

輸入水平自動掃描的終點，終點必須選擇預設點(你必須先將預設點設定完成，如 4.2.2 步驟)的其中一點。

按下[OFF]鍵即完成終點的設定，並且快速球將馬上運行水平迴轉。

PS: 如果起始點與終點是設定同一個預置點，如此快速球將會作 360 度水平迴轉。輸入的起始點及終點必須在 1 到 64 預置點內的其中一個號碼

5 鏡頭變焦全景圖像：[WIDE]

顯示：*** Zoom Wide ***

6 鏡頭變焦特寫圖像：[TELE]

顯示：*** Zoom Tele ***

7 調整鏡頭聚焦遠：[FAR]

顯示：*** Far ***

8 調整鏡頭聚焦近：[NEAR]

顯示：*** Near ***

9 鏡頭光圈開：[OPEN]

顯示：*** Open ***

10 鏡頭光圈關：[CLOSE]

顯示：*** Close ***

11 控制指令

N	Control Object	Keyboard Operation Definition
---	----------------	-------------------------------

Value No.		[SET] + N + [ENTER]	[PRESET] + N + [ENTER]
86	Auto slow shutter for S1&S2&S8	OFF	ON
87	IR Filter AUTO for S2&S5&S8		ON
88	IR Filter IN (color mode) S2&S5		ON
89	IR Filter OUT (black-white mode) S2&S5&S8		ON
90	Back light	OFF	ON/AUTO
91	Digit ZOOM	OFF	ON
92	PAN SCAN SETTING		START point
93			STOP point
94	Zoom/Pan speed limit	OFF	ON
95	Camera Manual setting	OFF	ON
97	Preset Tour(preset 1 ~ 16 point)	OFF	ON
98	OSD Display	OFF	ON
99	Auto PAN Scan	OFF	ON

12 對協定的操作:

(3) 顯示當前協定: [F1] + 61 + [ON]

(4) 更改協定: 先顯示當前協定,再按[WIDE]或[TELE]切換協定,選定協定後按[OFF]則將選定協定設為當前協定,如按其他鍵,則視為取消改動,協定不變;

13 主副控制操作:

按[F1] + 62 + [ON]則 PORT2 通訊口做為一般輸出通訊口;

按[F1] + 62 + [OFF]則 PORT1 通訊口做為副控通訊輸入口;也就是將副控設備的控制埠接到 PORT1 埠上,將本鍵盤做為主控制鍵盤,共同通過 PORT2 去控制終端設備; 連接如下圖

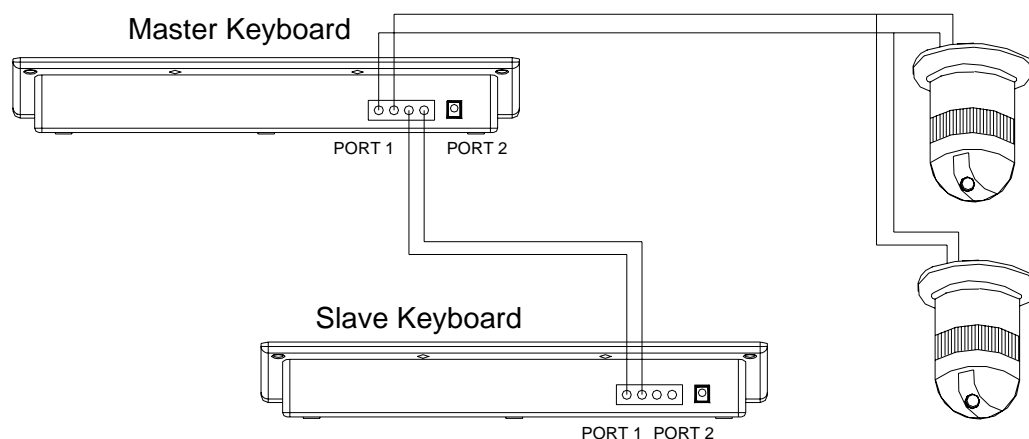

14 當快速球有選單時,選單操作如下;

1、按照表中的操作方式打開功能表

- 2、利用[WIDE]/[TELE]鍵可上下滾動光帶，以選擇功能表選項
- 3、利用[FAR]/[NEAR]鍵可改變所選的功能表選項的狀態
- 4、功能表設置好後，按照表中的操作方式關閉功能表

*注：以上 1—11 所示部分功能的實現由使用協定及內置攝像機的型號決定。

15 搖杆控制雲台如下圖：

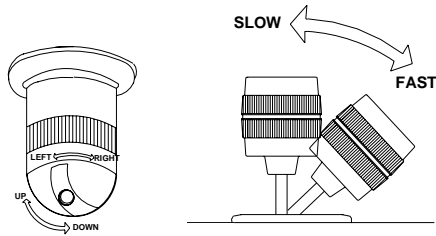

15.1 使用變速搖杆可以隨意控制攝像機電動雲台的旋轉/俯仰的方向、速度。旋轉/俯仰的速度是依據如右圖所示的操作搖杆的角度而決定的，通過改變搖杆的傾斜角度大小可以均勻調整轉速，轉動掃描過程中，攝像機會自動聚焦保持畫面清晰。

15.2 如你使用 3 維搖桿，你只需要搖桿上旋轉即可做鏡頭的 zoom in/out, 向右旋轉為 ZOOM IN, 向左旋轉為 ZOOM OUT, 如下圖所示:

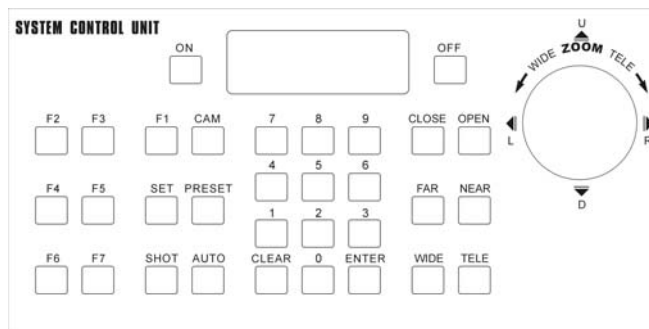

五、安裝連接

5.1 注意：在接線前請仔細閱讀鍵盤及高速球的使用說明書，任何不正確的接線可能導致設備的永久損壞。接線時請注意先將所有設備電源關斷，設備之間通訊線的連接必須用帶屏障的雙絞線，在架設電纜時，應盡可能地避開高壓線路或其他可能的干擾線。

鍵盤控制器控制多台球形攝像機的接法如下圖

串接方式

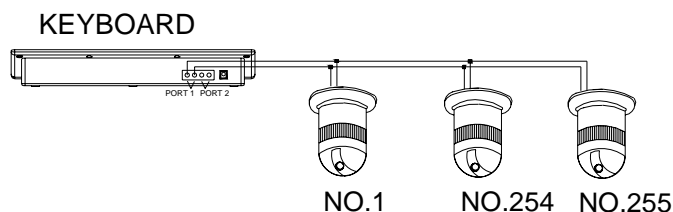

星狀方式

